

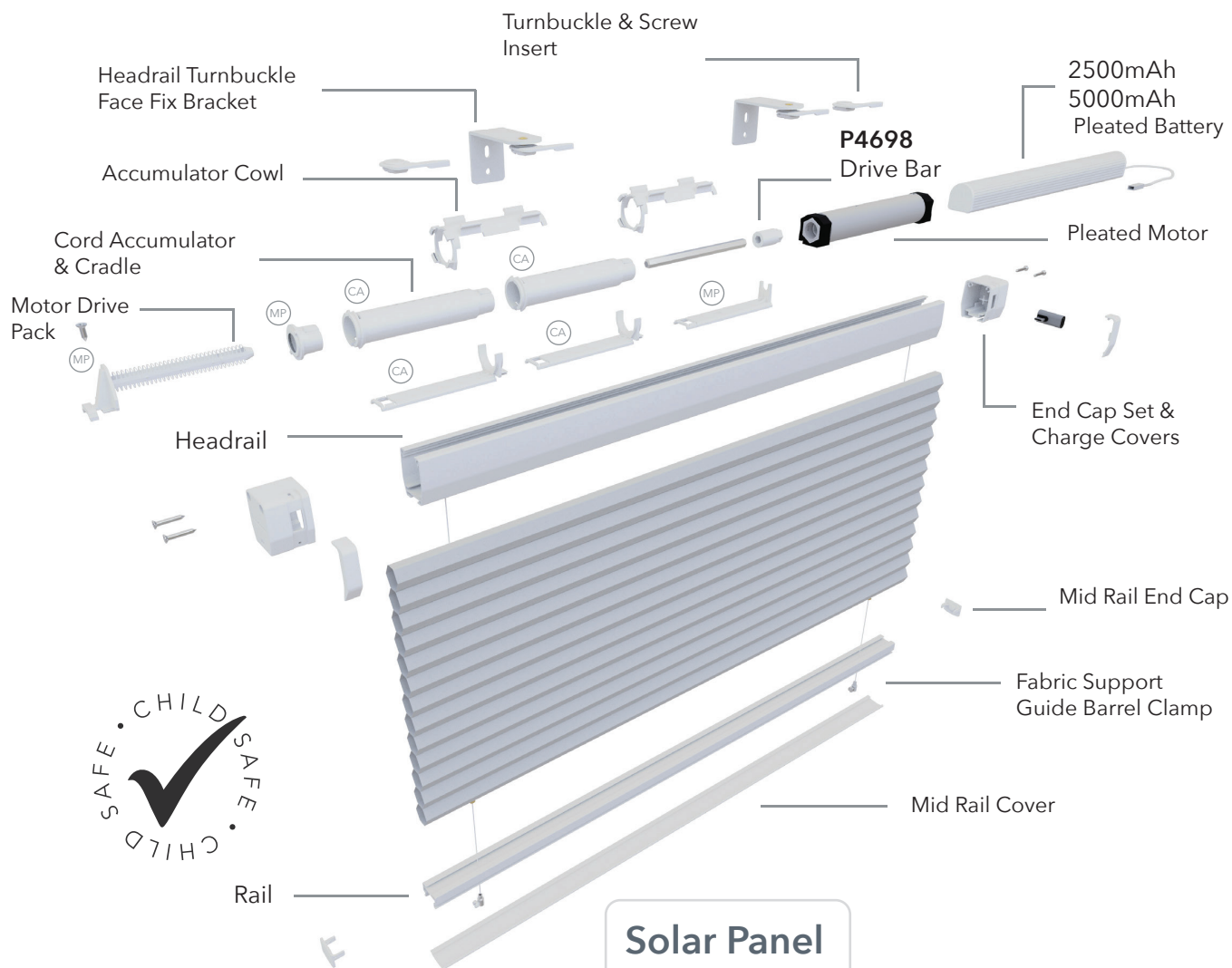

# **BLINDTEX HONEYCOMB FREEHANG MOTORISED SYSTEM**

RECHARGEABLE BATTERY 0.6Nm

# BLINDTEX HONEY COMB FREEHANG MOTORISED SYSTEM



**R1-2180CH**  
Single Channel  
Remote Control



**R6-2185CH**  
6 Channel  
Remote Control



**R16-2190CH\***  
16 Channel  
Remote Control



Smart Hub

## MOTORISED HONEYCOMB SYSTEM

- Operate blinds effortlessly and economically with the One Touch® lithium rechargeable Pleated motor.
- Quieter Motor.
- Easy & quick installation, no wiring needed.
- Child safe by design. Set up to four limits to stop blind at your chosen height.
- Motor weight capacity of 3.6kg for blinds up to 3m wide.

- 6-3 months operation between charges.
- Conveniently operate singular or multiple blinds with a One Touch® remote controls.
- Can be operated with Smart Hub. Using WiFi any One Touch® blinds can be operated remotely via the app on a phone/tablet or by voice command with Amazon Echo, Google Home and Siri.

# BLINDTEX HONEY COMB FREEHANG MOTORISED SYSTEM

## HONEY COMB MOTOR

Lithium Motor

• 2500 mAh Battery

• 5000 mAh Battery

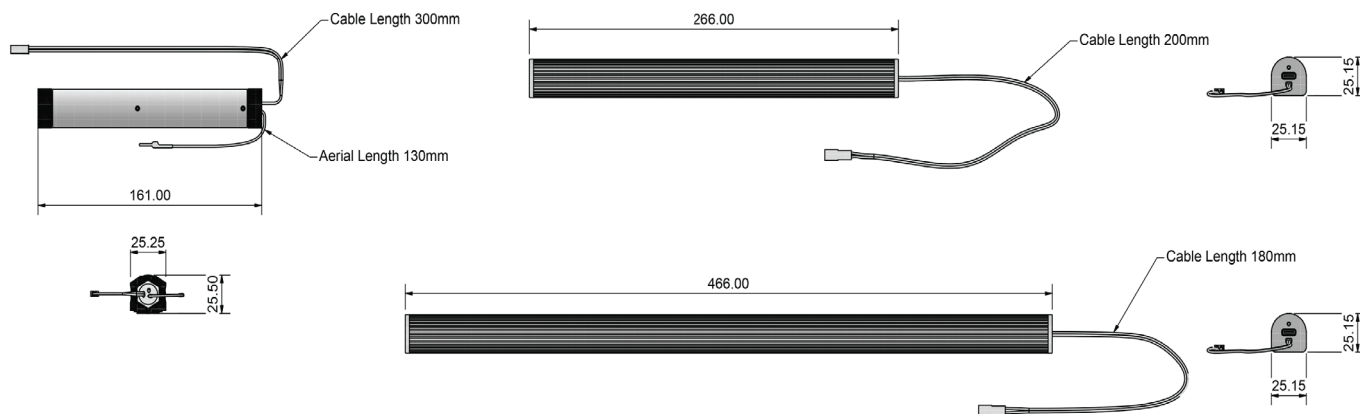

### PERFORMANCE PARAMETERS:

#### Honey Comb Motor

Rated Torque	0.3Nm
Speed RPM	35/30/25rpm adjustable
Rated Voltage	DC7.4V
Rated Power	8.9W
Rated Current	1.2A
IP Class	IP20
Control Mode	RF Remote Control Smart Control
Blind Width Battery in blind	TBC
Blind Width Battery outside blind	TBC
Weight Capacity	1kg
Power Source	Re-chargeable (plug-in charger or solar panel)

### HONEY COMB SYSTEM

P4004 Honey Comb Motorised Headrail

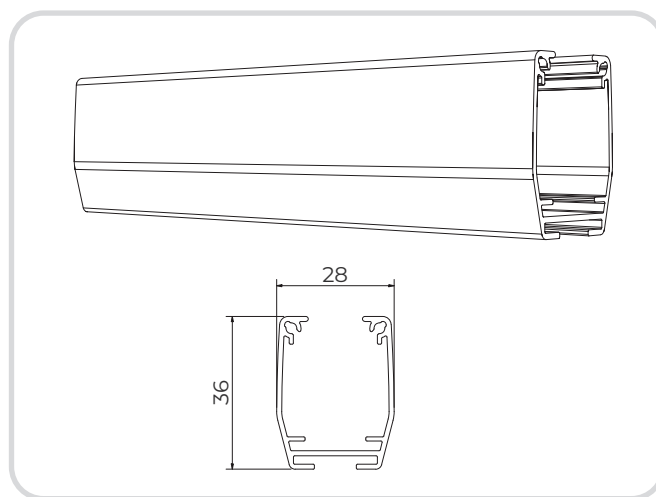

### SMART ACTIVATOR



## HARDWARE SPECIFICATION

### Motorised Lift System

- Our motorised blinds are manufactured using the dedicated motorised headrail.
- The fabrics are secured into the head & intermediate rails with aluminium slatting.
- The end caps are moulded using UV stabilised Nylon 6.
- The blinds are child safe with no loose cords.

### Maintenance

- All of the blind system components are manufactured using aluminium, treated steel and plastic.
- They do not present any corrosion problems in normal environments.
- The system has been designed for a smooth operation, together with a rigidity to prolong the window blind's working life.

### Performance

- To ensure a positive performance, Blindtex component units are designed and manufactured in the UK using prime quality plastic materials.
- 10 year life cycle testing is done to ensure long lasting performance.

### System Options

- Motorised freehang & skylight blinds.
- Perfect Fit International motorised blinds.
- Motorised fan blinds for gable end.

### Operation

- Control using our 6, 1 or 16 channel remote control.



**Innov8 Products FZC**  
**Area M6 - 10 SAIF Zone, Sharjah,**  
**United Arab Emirates**



**Phone: +971 6557 8051**



**Email: [sales@blindtex.com](mailto:sales@blindtex.com)**



**Web: [www.blindtex.com](http://www.blindtex.com)**

### **Blindtex UK**

4B Wigan Road,  
Bolton, Lancashire,  
BL3 5PZ - UK  
Tel: **+44 120 495 4999**  
Web: [www.blindtex.co.uk](http://www.blindtex.co.uk)  
Email: [sales@blindtex.co.uk](mailto:sales@blindtex.co.uk)

### **Blindtex BAHRAIN**

Office No. 728, Building No. 33,  
Road No. 1802, Block No. 318  
Exhibition road, Kingdom of Bahrain  
Tel: **+973 3222 0440**  
Web: [www.blindtex.bh](http://www.blindtex.bh)  
Email: [bahrain@blindtex.com](mailto:bahrain@blindtex.com)